

CONTAINERWAGEN | CONTAINER CARRIER

Sgmmns(s) 47'



Technische Daten | technical details

■ Eigengewicht Tare weight	Ca. 18t Approx. 18 t	■ Min. befahrbarer Kurvenradius Min. curve-radius	120 m (im Zugverband) 120 m (in block train)
■ Max. Zuladung Max. load	72t	■ Max. Geschwindigkeit Max. speed	120 km/h
■ Radsatzlast Axle load	22,5 t 22.5 t	■ Ladelänge Loading length	14.400 mm 14,400 mm
■ Raddurchmesser Wheel diameter	920 mm	■ Ladelänge in Fuß Loading length in feet	47 ft
■ Länge über Puffer, gesamt Total length over buffers	15.640 mm 15,640 mm	■ Ladebreite Loading width	2.600 mm 2,600 mm
■ Abstand äußere Radsätze Clearance: outer wheelsets	12.000 mm 12,000 mm	■ Ladehöhe über SOK, unbeladen Loading height above top of rail, unloaded	1.155 mm 1,155 mm
■ Bremse Brake	Ch-GP-A 16"	■ Fährbootfähigkeit Ferry boat capability	2° 30'
■ Sohlenkategorie Brake block category	LL-/K-Sohle LL/composite brake block		



Wagen für den kombinierten Verkehr mit einem maximalen Ladegewicht von 72 t. Optimierte für 20'-Tank- und -Schüttgutcontainer, schwere 40'- und 45'-Container sowie auch schwere Wechselbehälter bis 7,15 m Länge.

Railcar for combined transport with a maximum loading weight of 72 t. Optimized for 20' tank and bulk containers, heavy 40' and 45' containers as well as heavy swap bodies up to 7.15 m length.

VTG Rail Europe GmbH
Nagelsweg 34
D-20097 Hamburg

Telefon +49 40 2354-0
info@vtg.com
www.vtg.com

CONTAINERWAGEN | CONTAINER CARRIER

Sgmmns(s) 47'

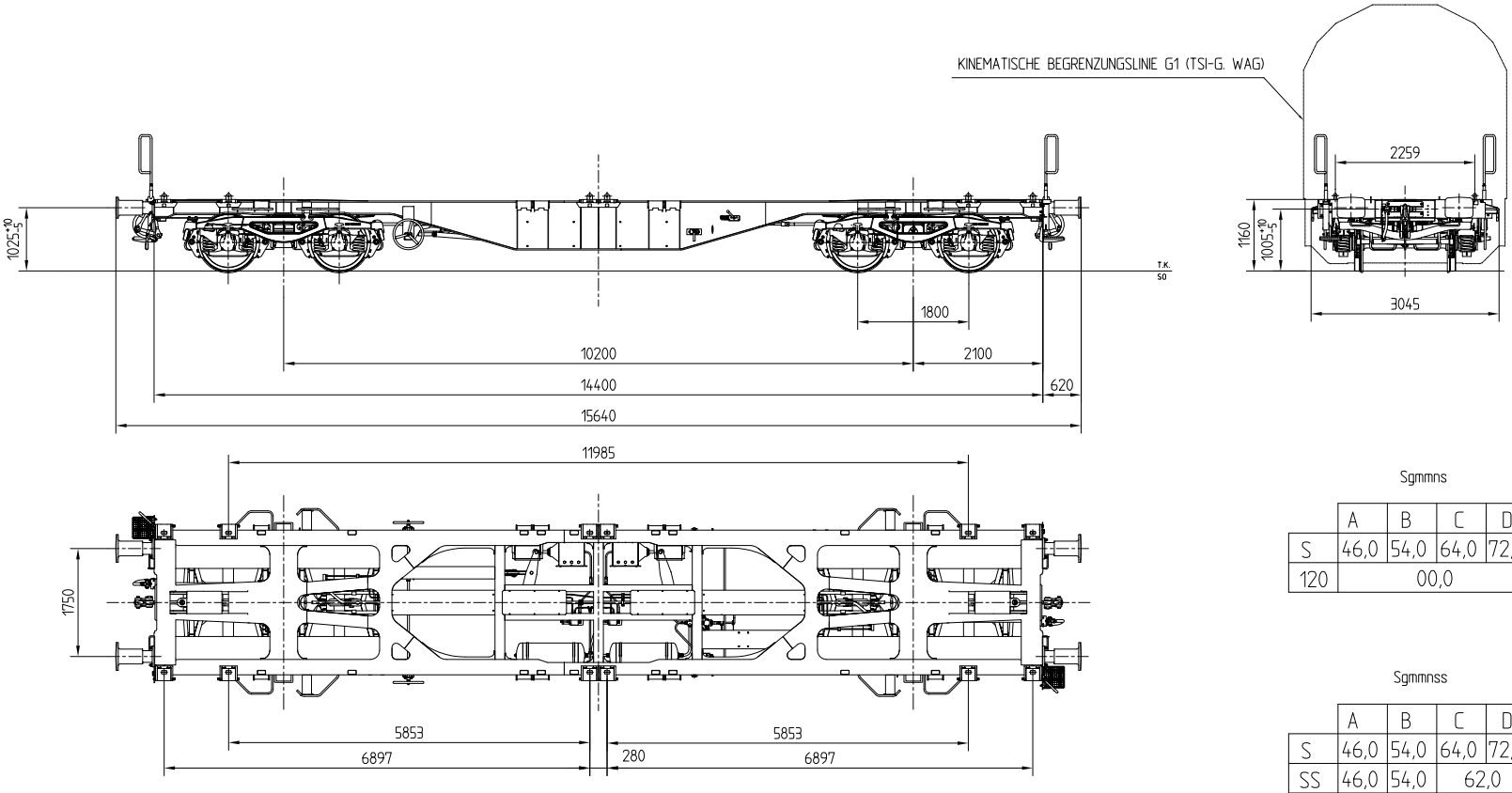

Sgmmns

	A	B	C	D
S	46,0	54,0	64,0	72,0
120	00,0			

Sgmmns

	A	B	C	D
S	46,0	54,0	64,0	72,0
SS	46,0	54,0	62,0	

Technische Änderungen vorbehalten/Specification subject to change

VTG Rail Europe GmbH
 Nagelsweg 34
 D-20097 Hamburg

 Telefon +49 40 2354-0
 info@vtg.com
 www.vtg.com